



**Head Start**

# Engaging Reluctant Families: A Systems Approach to Increasing Family Involvement

**15<sup>th</sup> Annual Birth to Three Institute**

**June 23, 2011**

**Laurie Phalen, M.Ed, MSW, LCSW**

**Montana Early Childhood Specialist/State Manager**

**Booz Allen Hamilton**

**Contractor to DHHS/ACF/OHS Region VIII**

# Engaging Reluctant Families



## Our Objectives

- Participants will increase their understanding of why families resist program engagement.
- Participants will increase their ability to identify the source of family resistance and how best to meet that source of resistance.
- Participants will increase their personal inventory of unique strategies to engage reluctant families.

# Engaging Reluctant Families



- Participants will increase their ability to identify the source of family resistance and how best to meet that source of resistance.
- Participants will increase their personal inventory of unique strategies to engage reluctant families.



## Relevant Performance Standards

- **45 CFR 1304.40(c)(1)(i), (ii) & (iii) Services to Pregnant Women Who are Enrolled in Programs Serving Pregnant Women, Infants and Toddlers**

(c) Services to pregnant women who are enrolled in programs serving pregnant women, infants, and toddlers.

(1) Early Head Start grantee and delegate agencies must assist pregnant women to access comprehensive prenatal and postpartum care, through referrals, immediately after enrollment in the program. This care must include:

# Engaging Reluctant Families



- (i) Early and continuing risk assessments, which include an assessment of nutritional status as well as nutrition counseling and food assistance, if necessary;
- (ii) Health promotion and treatment, including medical and dental examinations on a schedule deemed appropriate by the attending health care providers as early in the pregnancy as possible; and
- (iii) Mental health interventions and follow-up, including substance abuse prevention and treatment services, as needed

# Engaging Reluctant Families



- **45 CFR 1304.40(a)(5); 1304.40(d)(1); 1304.40(e)(3); 1304.40(f)(1); 1304.23(d) Parent Involvement**

1304.40(a)(5)

(5) Meetings and interactions with families must be respectful of each family's diversity and cultural and ethnic background.

1304.40(d)(1)

(d) Parent involvement  general. (1) In addition to involving parents in program policy-making and operations (see 45 CFR 1304.50), grantee and delegate agencies must provide parent involvement and education activities that are responsive to the ongoing and expressed needs of the parents, both as

•

# Engaging Reluctant Families



individuals and as members of a group. Other community agencies should be encouraged to assist in the planning and implementation of such programs.

## 1304.40(e)(3)

(3) Grantee and delegate agencies must provide opportunities for parents to enhance their parenting skills, knowledge, and understanding of the educational and developmental needs and activities of their children and to share concerns about their children with program staff (see 45 CFR 1304.21 for additional requirements related to parent involvement).

# Engaging Reluctant Families



## 1304.40(f)(1)

(f) Parent involvement in health, nutrition, and mental health education. (1) Grantee and delegate agencies must provide medical, dental, nutrition, and mental health education programs for program staff, parents, and families.

## 1304.23(d)

(d) Family assistance with nutrition. Parent education activities must include opportunities to assist individual families with food preparation and nutritional skills.



# Engaging Reluctant Families



- How do you change strong program resistance to stronger program commitment?
- How do you communicate the benefits of involvement and compliance to a non-compliant family?
- Why are some families angry, non-compliant or just difficult to work with *and* whose responsibility is it to make the relationship work?

# Engaging Reluctant Families



- Family engagement starts with the first contact, the first phone call, the forms used, at the center door and the first home visit.
- Family engagement is the responsibility of all staff.

# Engaging Reluctant Families



- Family engagement starts with the first contact, the first phone call, the forms used, at the center door and the first home visit.
  - What is the first impression the program gives?
  - Have you filled out your own program paperwork?
  - Have you thought of what it might be like to answer the questions you ask a family minutes after meeting?
  - Who is best able to change their way of relationship building?

# Engaging Reluctant Families



- Family engagement is the responsibility of all staff.
  - Who does your family interact with at your program?
    - Bus driver?
    - Receptionist?
    - Maintenance?
    - Teaching staff?
    - Leadership staff?
    - You?



## Program

- How family friendly is your program?
- The support of staff is critical to family engagement. How do you provide leadership or ask for leadership that enhances family engagement, especially engagement of reluctant families?



## Families

- Who are those reluctant families and why are they so resistant?
- What is their source of hostility or non-compliance?
  - Is anger a symptom of fear, insecurity?
  - Is non-compliance due to lack of understanding, inability to read, lack of transportation or housing?



## Family Service Workers

- Seasoned successful family workers have discovered how to find the chink in the armor, that little toe hold that gives the worker emotional access to the families they work with.

# Engaging Reluctant Families



## A Systems Approach

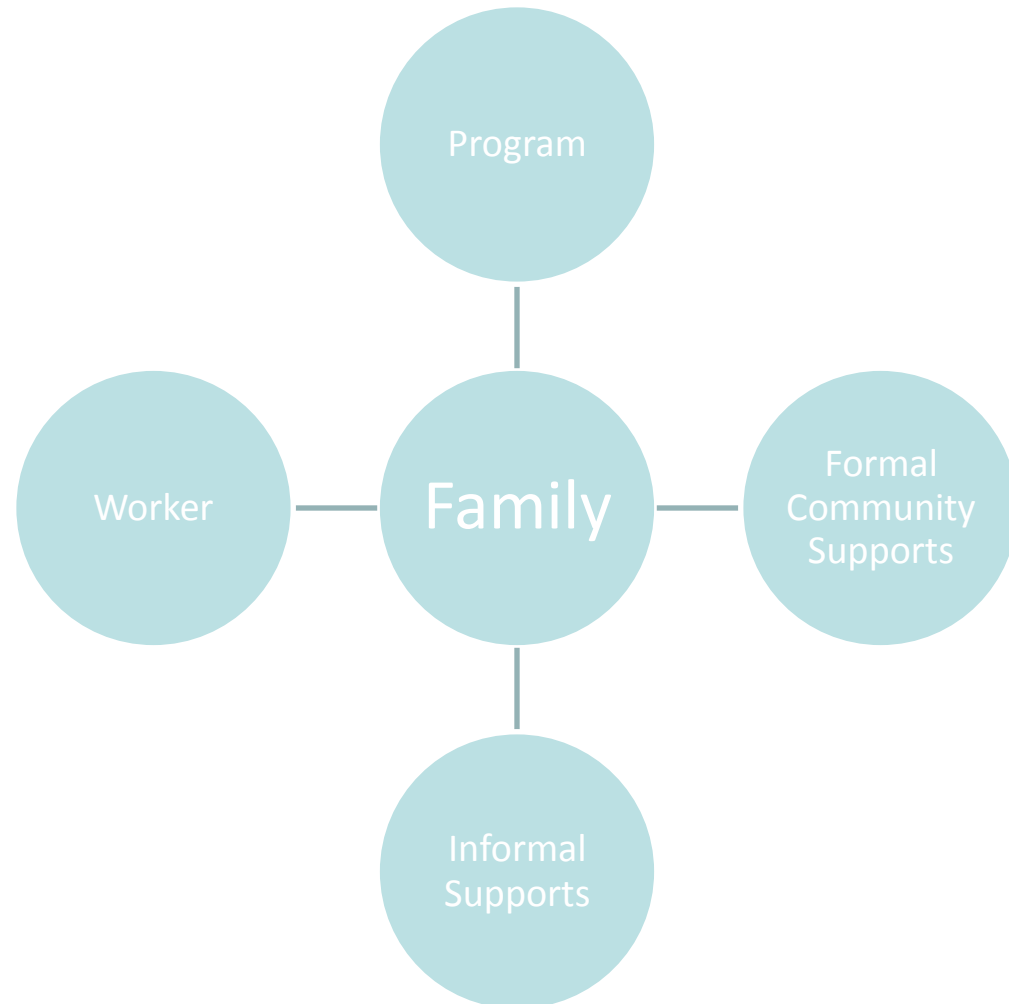



# Engaging Reluctant Families



Where  
can you  
be an  
agent of  
change?

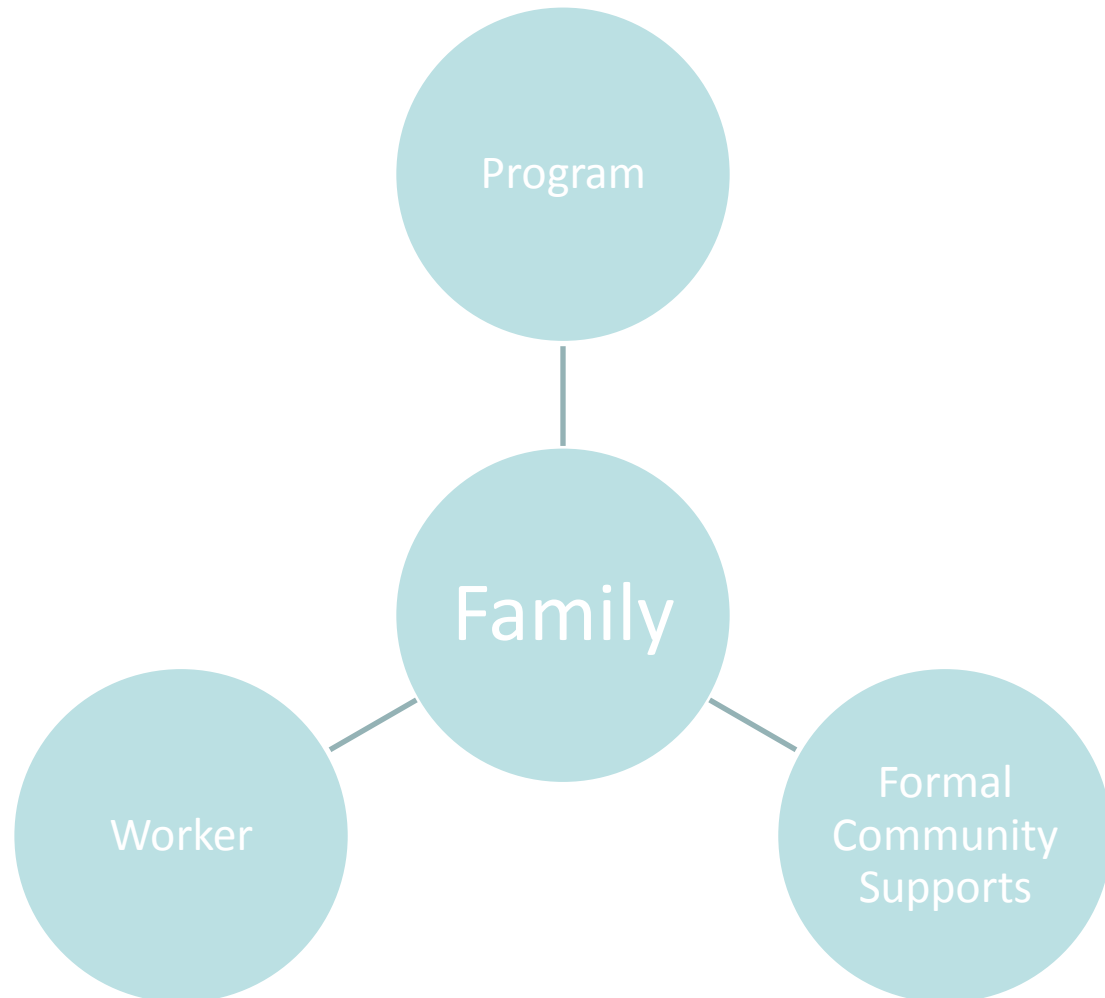

# Engaging Reluctant Families



- Worker
- Family
- Program

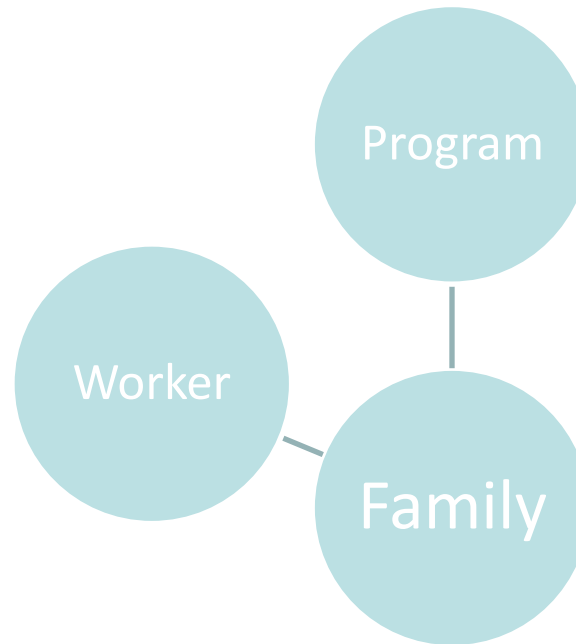

# Engaging Reluctant Families



## Worker

- Who are you?
- What is your role?
- How is the role of family worker valued within your program?
- How is the role of family worker valued by families?

# Engaging Reluctant Families



## Family

- Who are your families?
- What is their role?
- How are families valued within your program?
- How are families valued by other families?



## Program

- Who is your program in the community?
- What is the role of your program in the community?
- How is your program valued within your program?
- How is your program valued by families?

# Engaging Reluctant Families



- Together worker's skill and the program culture determine the *potential* effectiveness of family engagement.

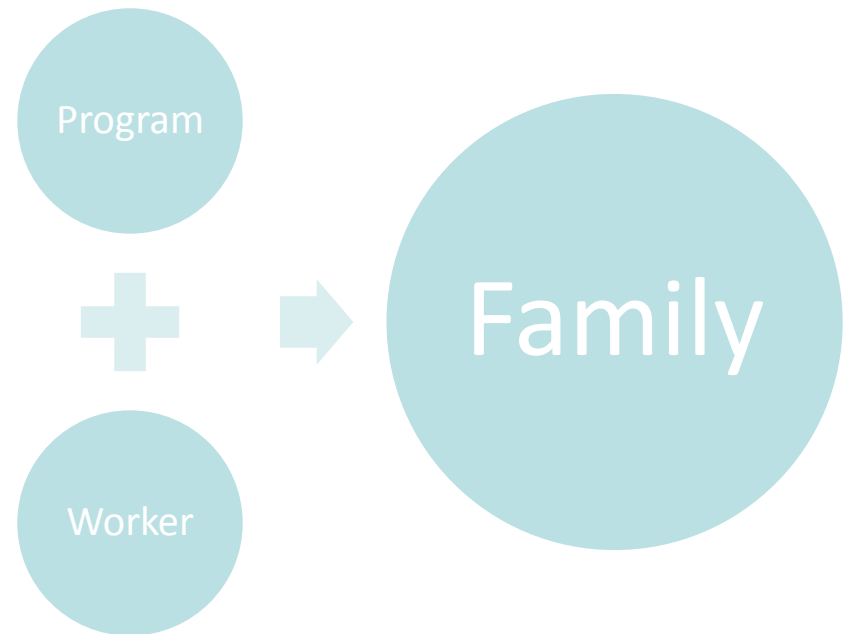

# Engaging Reluctant Families



- At your foundation who are you and what is your role as a family worker?



# Advocate



# Engaging Reluctant Families



A  
D  
V  
O  
C  
A  
T  
E

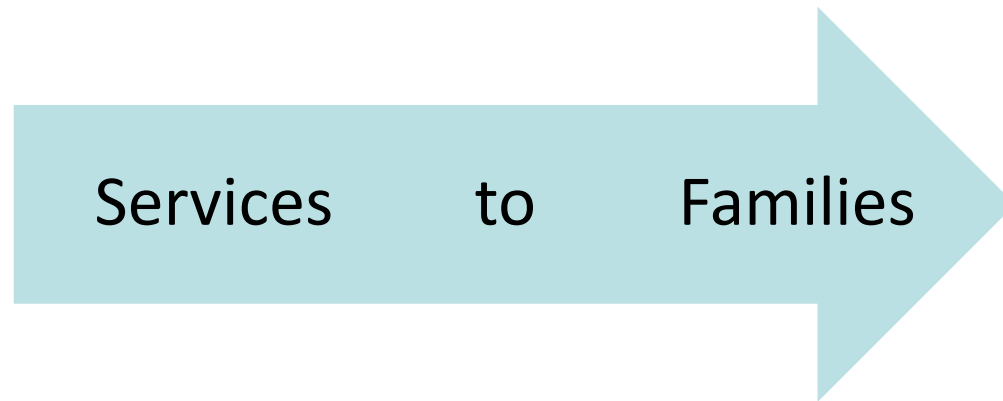

# Engaging Reluctant Families



A D V O C A T E



Advocating for families in the community



Advocating for families in the program

A D V O C A T E

# Engaging Reluctant Families



## Advocating for Families

A  
D  
V  
O  
C  
A  
T  
E



## Family Advocate

- A
  - Ask families what are their hopes and dreams for their child and family
  - Affirm their hopes and dreams



## Family Advocate

- A Ask and affirm family hopes and dreams
- D
  - Discover who the family is.



## Family Advocate

- A Ask and affirm family hopes and dreams
- D Discover who the family is
- V
  - Validate and value what you learn about the family



## Family Advocate

- A Ask and affirm family hopes and dreams
- D Discover who the family is
- V Validate and value what you learn about the family
- O
  - Organic relationships



## Family Advocate

- A Ask and affirm family hopes and dreams
- D Discover who the family is
- V Validate and value the family
- O Organic relationships
- C
  - Create community connections





## Family Advocate

- A Ask and affirm family hopes and dreams
- D Discover who the family is
- V Validate and value the family
- O Organic relationships
- C Create community connections
- A
  - Assist families develop goals toward their hopes and dreams

# Engaging Reluctant Families



## Family Advocate

- A Ask and affirm family hopes and dreams
- D Discover who the family is
- V Validate and value the family
- O Organic relationships
- C Create community connections
- A Assist families develop goals toward their hopes and dreams
- T
  - Trust the process

# Engaging Reluctant Families



## Family Advocate

- A Ask and affirm family hopes and dreams
- D Discover who the family is
- V Validate and value the family
- O Organic relationships
- C Create community connections
- A Assist families develop goals toward their hopes and dreams
- T Trust the process
- E

# Engaging Reluctant Families



## Family Advocate

- Ask and affirm family hopes and dreams
- Discover who the family is
- Validate and value the family
- Organic relationships
- Create a connection
- Assist families develop goals toward their hopes and dreams
- Trust the process
- Engage, Empower, Educate

# Engaging Reluctant Families



## Advocating for Families within the Program

A  
D  
V  
O  
C  
A  
T  
E

# Engaging Reluctant Families



## Program Advocate

- Ask and affirm **program** hopes and dreams
- Discover who the **program** is
- Validate and value the **program**
- Organic relationships
- Create a connection
- Assist **program** develop goals toward their hopes and dreams
- Trust the process
- Engage, Empower, Educate

# Engaging Reluctant Families

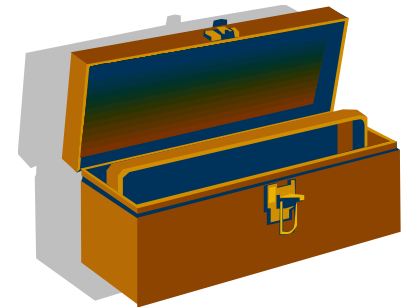
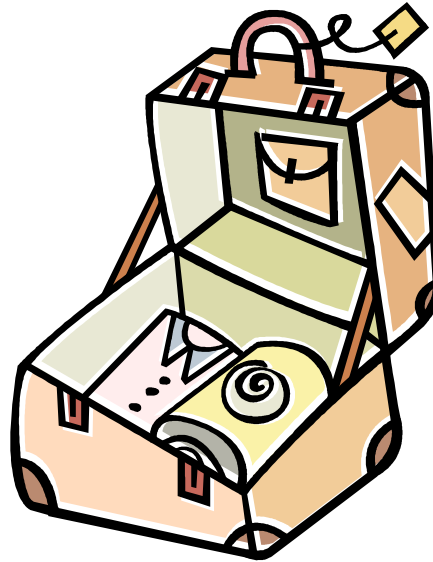
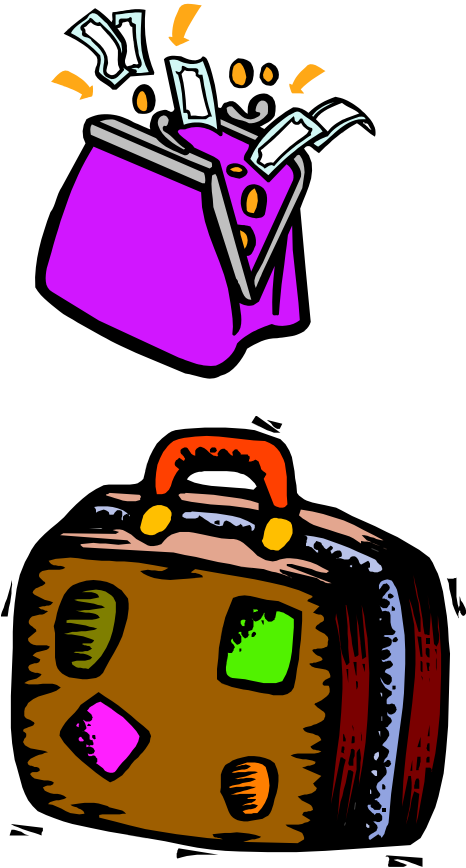



## A call to action

- Look at both of your advocacy lists
- Pick the top three in each list
- Number them in order of which you want to put into action first
- Develop an action plan



# Engaging Reluctant Families



| Goal | Task | Responsible Person | Start Date | Evaluation Date |
|------|------|--------------------|------------|-----------------|
|      |      |                    |            |                 |
|      |      |                    |            |                 |
|      |      |                    |            |                 |
|      |      |                    |            |                 |
|      |      |                    |            |                 |
|      |      |                    |            |                 |
|      |      |                    |            |                 |
|      |      |                    |            |                 |

# Engaging Reluctant Families



## Resources

Early Childhood Learning and Knowledge Center  
Parent/Family Engagement

<http://eclkc.ohs.acf.hhs.gov/hslc/tta/system/family/Family%20and%20Community%20Partnerships/ew%20Parental%20Involvement;cGhhbGVubGF1cmll>

Early Childhood Learning and Knowledge Center  
Parent, Family and Community Engagement

<http://eclkc.ohs.acf.hhs.gov/hslc/tta/system/family/Family%20and%20Community%20Partnerships>

# Engaging Reluctant Families



This presentation was co-developed by Region VIII Office of Head Start (OHS), and its Technical Assistance contractor, Booz Allen Hamilton. Interpretations and conclusions contained in this presentation are those of the author and do not necessarily reflect the views of the U.S. Department of Health and Human Services or Booz Allen Hamilton.

We hope you find the presentation helpful. Should you need additional information about this topic, or wish to modify or adapt all or parts of this presentation for other purposes, please contact the following individual:

Laurie Phalen, M.Ed, MSW, LCSW  
Montana ECE Specialist/Manager  
Booz Allen Hamilton  
[phalen\\_laurie@bah.com](mailto:phalen_laurie@bah.com)

When using or adapting the content of this presentation for educational purposes, please use the following citation:

Booz Allen Hamilton – 2011  
Engaging Reluctant Families: A Systems  
Approach to Increasing Family Involvement